

SIEMENS

de Installationsanleitung für autorisiertes Personal
en Installation Instructions for authorized personnel
fr Instructions d'installation pour personnel qualifié
nl Installatie-aanwijzing voor bevoegd personeel
it Istruzioni di montaggio per personale autorizzato
es Instrucciones de montaje para personal autorizado

Thermostaten
Thermostats
Thermostats
Thermostats
Termostati
Termóstatos

RAK-T...H.®
RAK-S...M.®



RAK-TR
IP43



RAK-TW
IP43 oder IP65



RAK-ST
IP43 oder IP65



RAK-TB
IP43

SIEMENS	
RAK-TW.1000S-H S55700-P116	TW: 15...95°C IP43 T 80 1-2:16(2.5) A; 1-3:6 (2.5) A
Origin: Germany	AC 24...250 V 50/60 Hz
Siemens Switzerland Ltd	

de Produktionsdatum: Jahr/Monat/Tag/Version
en Date of production: Year/Month/Day/Version
fr Date de production: année/mois/jour/Version
nl Productiedatum: Jaar/Maand/Dag/Versie
it Data di produzione: Anno/Mese/Giorno/Versione
es Fecha de Producción: Año/Mes/Día/Version

de Montage, Einbaulage, IP65
fr Montage, Positions de montage, IP65
it Montaggio, Installazione, IP65

en Mounting, Mounting position, IP65
nl Montage, IP65
es Montaje, Posición de montaje, IP65

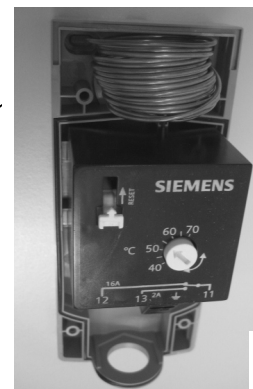
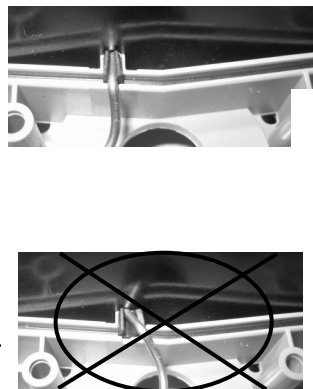
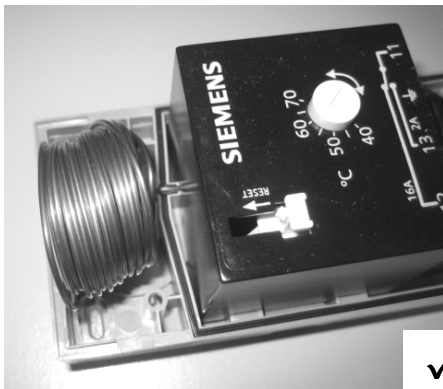

de Montagehinweise
nl Montage aanwijzingen

en Mounting notes
it Indicazioni di montaggio

fr Indication pour le montage
es Notas de montaje

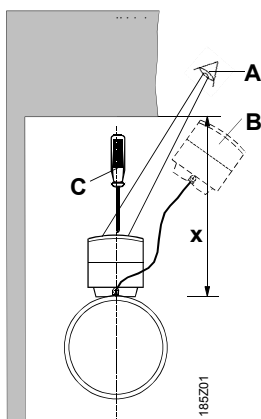

de **Montageort** möglichst trocken und staubfrei / **X** min. 250 mm Freiraum für
A Freie Sicht in das Gerät (Verstellen, Kontrolle vorhandener Einstellungen)
B Ausbauen resp. Einbauen / **C** Öffnen des Gerätes (Sollwerteneinstellungen)

en **Mounting location** dry and dust-free / **X** min. 250 mm clearance for
A Clear view (adjustments, checking existing settings)
B Removal or mounting / **C** Opening (setpoint adjustments)

fr **Lieu de montage** le moins humide et poussiéreux possible / **X** min. 250 mm de place libre pour
A bonne accessibilité à l'appareil (réglage, contrôle des réglages en vigueur)
B démontage et remontage / **C** ouverture de l'appareil (réglage des consignes)

nl **Montageplaats** droog en stofvrij / **X** min. 250 mm vrije ruimte voor
A vrij zicht in het apparaat (instellen, controleren huidige instelling)
B in- resp. uitbouwen / **C** openen van het apparaat (gewenste waarde instelling)

it **Posto per l'installazione** possibilmente asciutto e senza polvere / **X** min. 250 mm di spazio per
A accedere all'apparecchio (impostazione e controllo)

B montaggio e smontaggio del termostato / **C** apertura e impostazione della temperatura desiderata

es **Lugar de montaje** seco y libre de polvo / **X** mín. 250 mm de espacio libre para
A Visualización clara (ajustes, verificación de ajustes existentes)
B Retirada o montaje / **C** Apertura (ajustes de consigna)

de	Geräte öffnen	en	Opening the unit
fr	Ouverture de l'appareil	nl	Apparaat openen
it	Apertura apparecchio	es	Apertura de la unidad

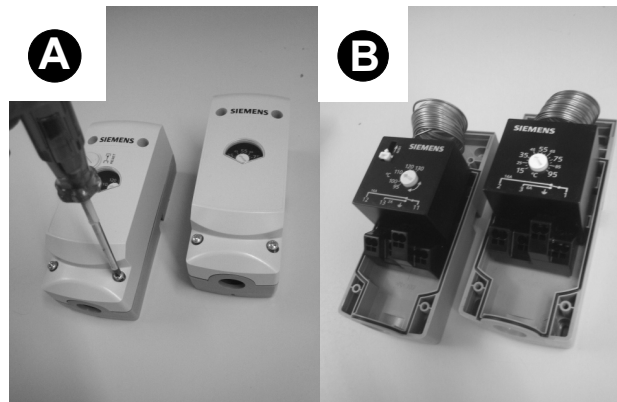

de	Einstellen der Temperatur-Sollwerte
en	Adjusting the temperature setpoints
fr	Réglage des consignes de température
nl	Instellen van de gewenste temperatuur waarde
it	Impostazione della temperatura
es	Adjuste de las consignas de temperatura

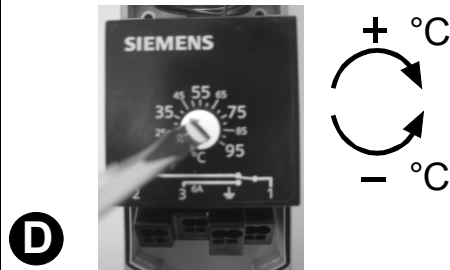

de	Einstellen der Grenzwerte
en	Adjusting temperature setpoints
fr	Réglage des consignes de température
nl	Instellen van de gewenste veiligheids-temperatuur
it	Impostazione della temperatura
es	Adjuste de las consignas de temperatura

de	Rohrmontage
en	Pipe mounting
fr	Montage sur tuyau
nl	Leidingmontage
it	Montaggio su tubo
es	Montaje en tubería

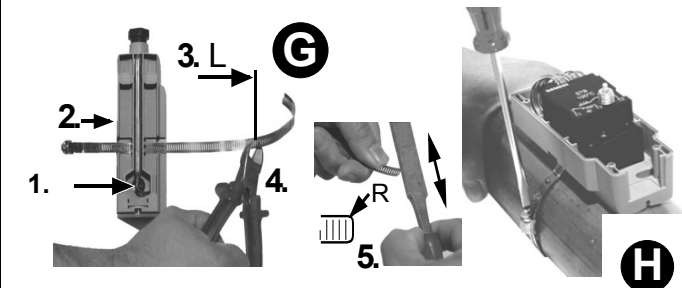
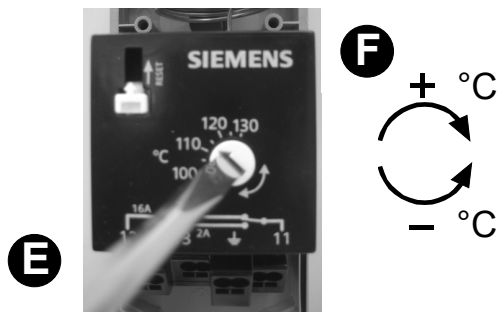

de	Schutzrohrmontage
en	Protection pocket mounting
fr	Montage sur gaine de protection
nl	Beschermhuls-montage
it	Montaggio su guaina
es	Montaje con vaina de protección

de	Wandmontage
en	Wall mounting
fr	Montage mural
nl	Wandmontage
it	Montaggio a parete
es	Montaje en pared

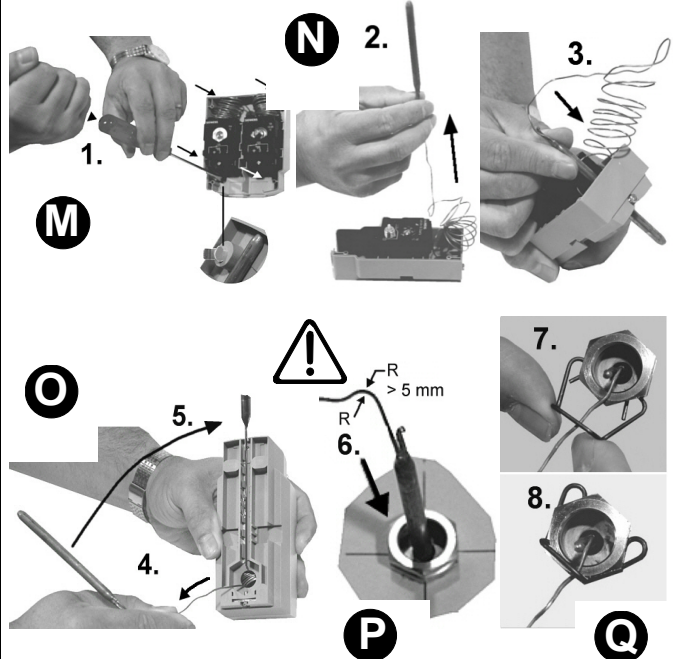
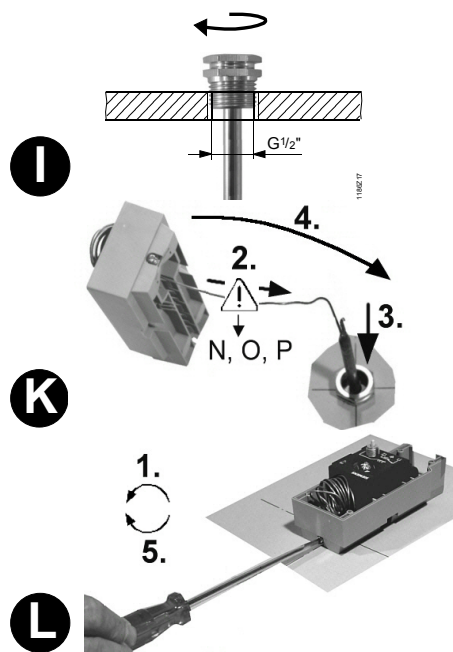

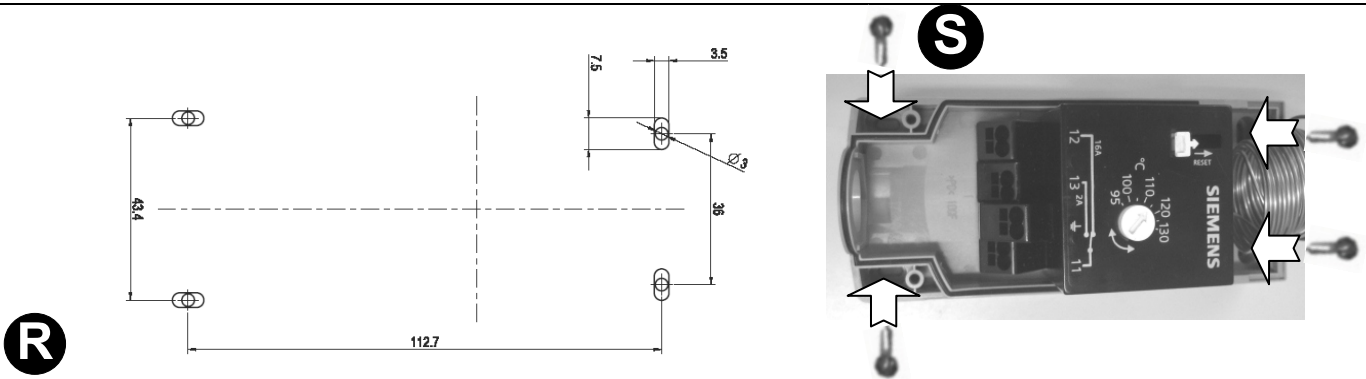

de Luftkanal-Montage
nl Luchtkanaalmontage

en Air duct mounting
it Montaggio condotta aria

fr Montage sur gaine d'air
es Montaje en conducto de aire

N 2. + 3. **O** 4.

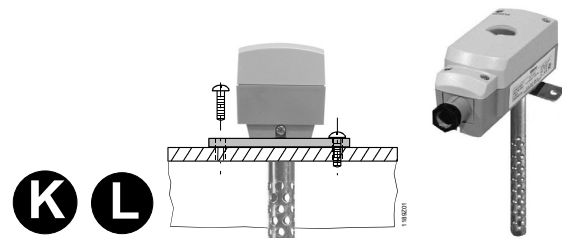
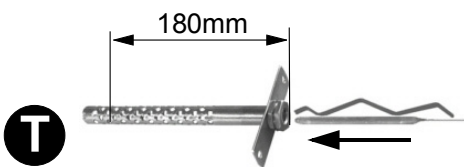

de Verdrahtung

en Wiring

fr Câblage

nl Bedrading

it Cablaggio

es Cableado

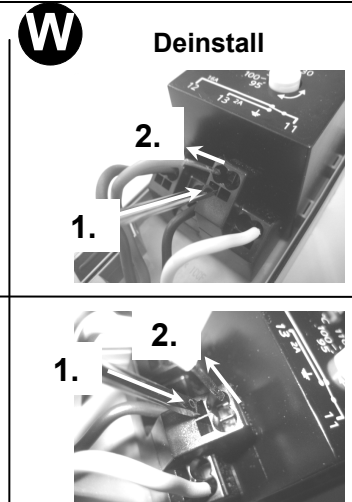
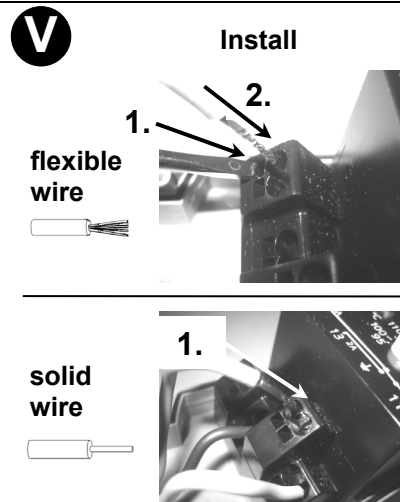
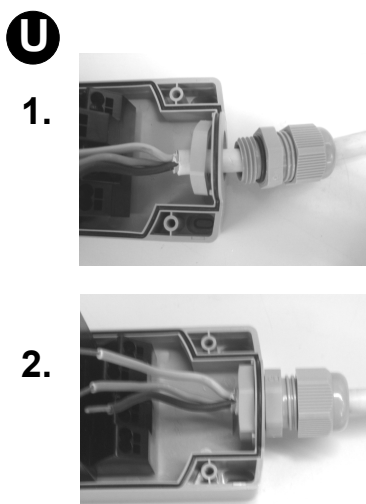

de Drehknopf
fr Bouton de réglage
it Manopola

en Setting knob
nl Draaiknop
es Botón de regulación

de Entriegelung
fr Verrouillage
it Ripristino (reset)

en Reset
nl Reset
es Reajuste

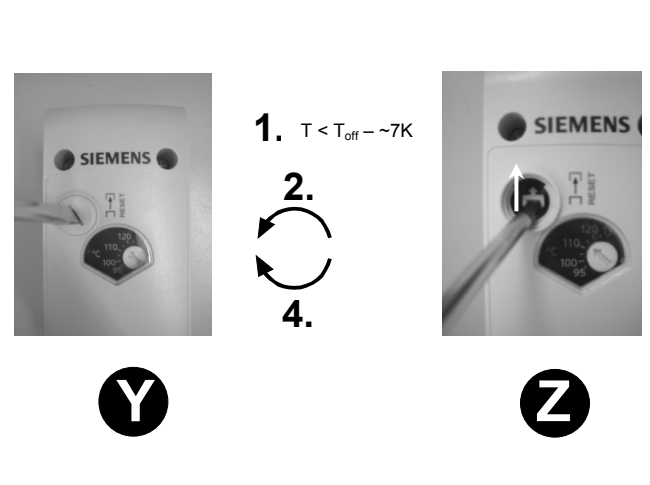
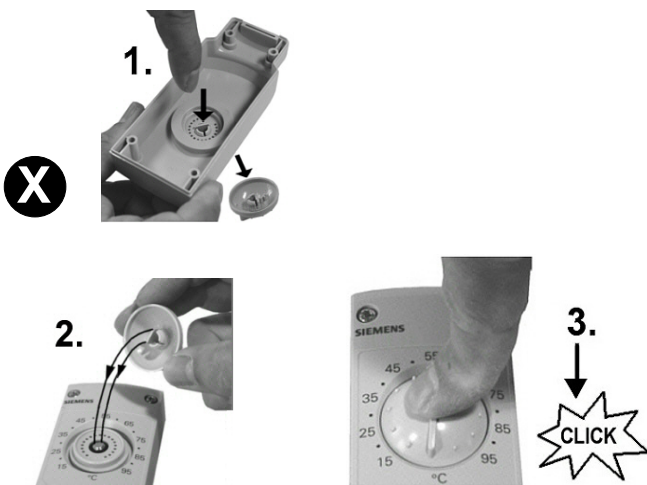

de	<ul style="list-style-type: none"> Spannungsbereich: AC 24...250 V (0.1...16A) Elektrische Anschlüsse und Schutzleiter: Push-in* Klemmen für Leiter 0.75...2,5 mm² STB manuell entriegeln erst möglich nach dem Abkühlen um ≥ -7 K unter die Ausschalttemperatur Verschmutzungsgrad: (2) Bemessung-Stossspannung 2.5kV 	<ul style="list-style-type: none"> Kein elektronisches Gerät Kapillarlänge zwischen 700mm - 1600 mm ¹⁾ Standards, Normen: CE, PED, DIN ¹⁾ Produktenorm EN 60 730-1 EN 60 730-2-9 EN 14597 <p>1) gemäss Geräteblättern</p>
en	<ul style="list-style-type: none"> Voltage range: AC 24...250 V (0.1...16A) Electrical connections and protective conductor: Push-in* terminals for conductor 0.75...2,5 mm².. STB can be reset only after the temperature has dropped ≥ -7 K below the switch-off temperature Degree of pollution: (2) Rated impulse voltage 2.5kV 	<ul style="list-style-type: none"> Device without electronic Capillary length: 700 mm - 1600 mm ¹⁾ Standards : CE, PED, DIN ¹⁾ Product standards EN 60 730-1 EN 60 730-2-9 EN 14597 <p>1) according to data sheets</p>
fr	<ul style="list-style-type: none"> Plage de tension: AC 24...250 V (0.1...16A) Raccordements électriques et fil de protection: bornes Push-in* pour fil de 0.75...2,5 mm² Déverrouillage STB manuel seulement possible après refroidissement ≥ -7 K en-dessous de la température de coupure Degré d'encrassement : (2) Tension assignée de tenue aux chocs: 2.5kV 	<ul style="list-style-type: none"> Appareil sans électronique Longueur du capillaire : 700 mm - 1600 mm ¹⁾ Normes et standards : CE, PED, DIN ¹⁾ Normes pour produits EN 60 730-1 EN 60 730-2-9 EN 14597 <p>1) voir fiches techniques</p>
nl	<ul style="list-style-type: none"> Spanningsbereik: AC 24...250 V (0.1...16A) Elektrische aansluiting en aarding: Push-in* klemmen voor aansluiting 0.75...2,5 mm² STB handmatig ontgrendelen pas mogelijk na afkoelen tot ≥ -7 K onder de uitschakeltemperatuur Vervuilinggraad: (2) Nominale piekspanning 2.5kV 	<ul style="list-style-type: none"> Regelaar bevat geen electronica Capillarlengte : 700 mm - 1600 mm ¹⁾ Standaards en normen: CE, PED, DIN ¹⁾ Productnorm EN 60 730-1 EN 60 730-2-9 EN 14597 <p>1) overeenkomstig apparatenblad</p>
it	<ul style="list-style-type: none"> Tensione d'alimentazione: AC 24...250 V (0.1...16A) Collegamento elettrico e di protezione: Morsetti Push-in* per collegamento 0.75...2,5 mm² STB ripristino manuale possibile solo dopo raffreddamento del sensore ≥ -7 K Grado d'inquinamento: (2) Tensione impulsiva nominale 2.5kV 	<ul style="list-style-type: none"> Dispositivo non elettronico Lunghezza capillare da 700 mm - 1600 mm ¹⁾ Norme e omologazioni: CE, PED, DIN ¹⁾ Norma prodotto EN 60 730-1 EN 60 730-2-9 EN 14597 <p>1) vedi fogli tecnici</p>
es	<ul style="list-style-type: none"> Rango de alimentación: AC 24...250 V (0.1...16A) Conexiones eléctricas y conductor protector: Bornas Push-in* para conexiones 0.75...2,5 mm².. STB pueden reajustarse sólo después de una caída de temperatura de ≥ -7 K por debajo de la temperatura de desconexión Grado de polución: (2) Tensión media por impulso 2.5kV 	<ul style="list-style-type: none"> Sin dispositivo electrónico Longitud del capilar 700 mm - 1600 mm ¹⁾ Estándares CE, PED, DIN ¹⁾ Estándares del producto EN 60 730-1 EN 60 730-2-9 EN 14597 <p>1) de acuerdo con las hojas técnicas</p>

de	Zubehördatenblatt N1193, N1194	
en	Data sheet with accessories N1193, N1194	
fr	Fiche produit des accessoires N1193, N1194	
nl	Apparatenblad met toebehoren N1193, N1194	
it	Foglio tecnico accessori N1193, N1194	
es	Hoja técnica con accesorios N1193, N1194	

Infrastructure & Cities

SIEMENS

EC - Declaration of conformity
CE - Déclaration de conformité
EG - Konformitätserklärung

Siemens Switzerland Ltd
 Building Technologies Division
 International Headquarters
 Ch. des Bains 22
 CH-6301 Zug

We
 Nous
 Ihr

declare under our sole responsibility that the product(s)
 déclarons sous notre seule responsabilité que le(s) produit(s)
 erkläre(n) in aufreger Verantwortung, dass das/die Produkt(e)

Product line: **Safety Limit Thermostats**

- RAK-ST.010FP-III
- RAK-ST.1300P-III
- RAK-ST.1430S-III
- RAK-ST.1600MP
- RAG-ST.1
- RAK-ST.030FP-III
- RAK-ST.1385III
- RAK-ST.020FP-III
- RAK-ST.1310P-III

CE - marking / CE - marquage / CE - Anbringung: **07**

to which this declaration relates is/are in conformity with the requirements of the following directive(s)
 auf welche(s) se réfèrent cette déclaration, est/sont conformé(s) aux prescriptions de la(s) directive(s)
 auf die/die sich diese Erklärung bezieht, konform ist/sind mit den Anforderungen der Richtlinie(n)

- 2004/108/EC Electromagnetic compatibility (EMC)
- 2006/95/EC Low Voltage (LVD)
- 87/23/EEC Pressure Equipment (PED), Module B+D (CE 0038)

This conformity was checked in accordance with the following harmonised EN standard(s)
 La conformité (in conformance) se(n) vérifia se(n) conformément à la(s) norme(s) EN-harmonisée(s)
 Die Konformität wurde überprüft anhand der harmonisierten EN-Norm(en)

- EN 60730-1:2000 +A1:2004 +A12:2003 +A13:2004 +A14:2005 +A15:2007
- EN 60730-2-9:2002 +A1:2003 +A12:2003 +A13:2004 +A14:2005 +A15:2007
- EN 50144-1:2005
- EN 61326-1:2006
- EN 14697:2005

Automatic electrical controls for household and similar use - General requirements
 Automatische elektrische Steuerungen für Haushalts- und ähnliche Anwendungen - Allgemeine Anforderungen
 Automatic electrical controls for household and similar use - Particular requirements for temperature sensing controls
 Automatische elektrische Steuerungen für Haushalts- und ähnliche Anwendungen - Besondere Anforderungen für Temperatursensoren
 Electromagnetic compatibility - Requirements for household appliances, electric tools and similar apparatus
 Elektromagnetische Verträglichkeit - Anforderungen für Haushaltsgeräte, elektrische Werkzeuge und ähnliche Vorrichtungen
 Electrical equipment for measurement, control and laboratory use - EMC requirements
 Elektrische Ausrüstung für Mess-, Steuer- und Labornutzung - EMC-Anforderungen
 Temperature control devices and temperature limiters for heat generating systems.

Control Products & Systems (CPS)

Control Products & Systems (CPS)

sig. I. V. Konrad Meier
 Head Product Quality Assurance
 IC BT CPS GDT EU HW PQA

sig. I. V. Walter Frei
 Head Thermostats EU
 IC BT CPS RAG TH THE

CE111204xx
 03-May-2012

1/1
 TeamCenter: 8000058512.B

1/1

TeamCenter: 8000058512.B