

VK41../VK81..

GAS CONTROLS FOR COMBINED VALVE AND IGNITION SYSTEM

INSTRUCTION SHEET

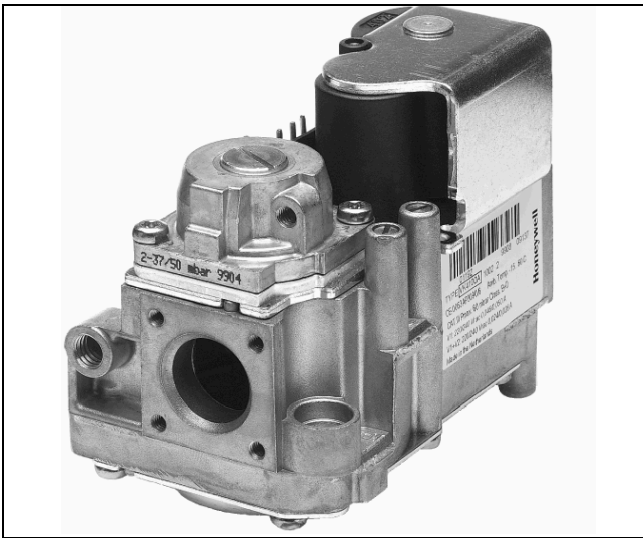

APPLICATION

The Combined Valve and Ignition system (CVI) has specially been developed for application in gas fired appliances with either intermittent pilot or direct burner ignition.

For this system, the VK41../VK81.. series gas controls have been designed to have the S4565/75/85 series ignition control attached directly onto the valve.

The combined system then provides programmed safe light up, flame supervision and regulation of gas flow to the main burner and/or pilot burner of the appliance.

The valve (types without pilot outlet) can as well be used as stand alone in direct burner ignition applications. A plug with integrated rectifier circuit then has to be used.

The VK41../VK81.. series gas controls are approved in accordance with European standards.

DESCRIPTION

The gas control holds a first electric on/off direct operator for opening the safety valve of class A or B according to EN 161 and a second electric on/off servo operator of class B, C or J according to EN 161.

The gas control comprises a standard body to which a range of features can be factory included to give various functional options.

The pressure regulator is in accordance with class B requirement of EN 88.

The gas control can handle the three gas families, manufactured gas, natural gas and LP gas.

SPECIFICATIONS

NOTE: Specifications for electrical modulation, electrical High-Low and other features are available on request.

Model

VK41.0: 220/240 Vrac, 50/60 Hz, with pilot outlet connection

VK41.5: 100 Vrac, 50/60 Hz or 220/240 Vrac, 50/60 Hz, without pilot outlet connection

VK81.0: 24 Vrac, 50/60 Hz, with pilot outlet connection

VK81.5: 24 Vrac, 50/60 Hz, without pilot outlet connection

Suffix A: fast opening with regulator

Suffix B: fast opening without regulator

Suffix C: softlite opening with regulator

Suffix D: softlite opening without regulator

Suffix M: fast opening with modulating regulator (Modureg)

Suffix N: softlite opening with modulating regulator (Modureg)

Suffix P: fast opening with High-Low regulator

Suffix Q: softlite opening with High-Low regulator

Dimensions

See fig. 1.

Ambient temperature

0 ... 60°C

-15 ... 60°C (on request)

Main gas connection

See table 1. and table 2.

$\frac{3}{8}$ " and $\frac{1}{2}$ " straight or elbow flanges are according to the torsion and bending stress of EN 126 group 2

Connections with G $\frac{1}{2}$ " or G $\frac{3}{4}$ " external thread fitted with nuts according to ISO 228-1 in combination with applicable sealing(s) withstand the torsion and bending stress of EN 126 group 1

Side outlet (optional) can be fitted direct to a burner manifold.

Pilot gas connection (where applicable)

M8 x 1 for 4 mm outer diameter tubing.

Pressure feedback connection

M5 threaded hole for connection between pressure regulator and combustion chamber of appliance.

Outlet pressure range

1.5 ... 20 mbar

2 ... 37 mbar with block function up to 50 mbar

5 ... 50 mbar

Maximum inlet pressure

60 mbar

Minimum regulation capacity

0.31 m³/h air

Closing time

< 1 second

Inlet	End outlet	Side outlet	Body length (mm)
Flanged	Flanged	--	105
Flanged	--	Flanged	105
Internal $\frac{3}{8}$ " ISO 7-1	--	Flanged	115
Internal $\frac{1}{2}$ " ISO 7-1	--	Flanged	115
Internal $\frac{1}{2}$ " ISO 7-1	Internal $\frac{1}{2}$ " ISO 7-1	--	115

Table 1: Standard valve connection

Inlet	End outlet	Side outlet	Body length (mm)
G $\frac{1}{2}$ "	G $\frac{1}{2}$ "	--	135
G $\frac{1}{2}$ "	Flanged	--	120
G $\frac{3}{4}$ "	G $\frac{3}{4}$ "	--	135
G $\frac{3}{4}$ "	Flanged	--	120
G $\frac{3}{4}$ "	--	Flanged	120
G $\frac{3}{4}$ "	Internal $\frac{1}{2}$ " ISO 7-1	--	120
G $\frac{1}{2}$ "	--	Flanged	120
Flanged	G $\frac{1}{2}$ "	--	120
Flanged	G $\frac{3}{4}$ "	--	120

Table 2: External thread valve connection

Minimum differential pressure

Model	DP min (mbar)
VK4105/VK8105	2.5
VK4115/VK8115	4
VK4125/VK8125	4

Table 3: Minimum differential pressure

Maximum operating pressure

The P_{max} indication on the housing of the gas control is the maximum pressure at which it functions safely. However, the maximum inlet pressure is limited by the pressure range of the pressure regulator concerned. (See table 4.)

Table 4: Operating pressure

Model	Pressure range (mbar)	Maximum inlet pressure (mbar)
with regulation	1.5 ... 20	30
	2 ... 37*	45
	5 ... 50*	60
without regulation	-	60

* This type can also be used for non regulation mode in LP applications when pressure regulator adjustment screw is clockwise turned down until it stops.

Versions up to 100 mbar maximum inlet pressure are available on request

Capacity

In m^3/h air at pressure drop as shown below. Capacity curves are available on request.

Model	Valve classification		DP (mbar)	Capacity
	1 st valve	2 nd valve		
VK4100/VK8100 VK4105/VK8105	B	J	3	3.4
VK4110/VK8110 VK4115/VK8115	B	C	5	4.4
VK4120/VK8120 VK4125/VK8125	B	B	5	2.2

Table 5: Capacity

NOTE 1.: Versions with side outlet connection have a $0.2 m^3/h$ air lower capacity.

NOTE 2.: Increased capacity versions are optional for types with suffix letter E, T and V.

NOTE 3.: $\frac{3}{4}$ " external thread versions have a $0.3 m^3/h$ air lower capacity.

Electrical connection

Molex 1.1 square pin headers

Mounting holes

Two mounting holes for thread forming M4 screws are located on the bottom of the gas control.

The four holes at inlet and outlet for mounting a flange on the gas control are provided with M4 thread with min. 6 mm full thread.

In case of side outlet the three holes for mounting a flange are provided with M5 thread with a minimum of 6 mm full thread.

Main valve opening characteristics

Softlite versions (See table 7.)

NOTE: For Softlite versions the Softlite pressure can be adjusted from the rated Softlite up to the desired value, but max. up to 20 mbar

Fast opening versions

For class C or J closing force 2nd valve the dead time is 0.5 s max. and the outlet pressure shall reach 80 % of the rated flow within 1 s from start of flow.

The class B closing force 2nd valve can also be provided with reduced opening speed, the max. dead time is then 1 s max. and the outlet pressure shall reach 5 mbar within 3 s from start of flow.

Table 6: Valve classification

Model	1 st valve		2 nd valve	
	Classification	Backpressure (mbar)	Classification	Backpressure (mbar)
VK4100/VK4105	B	50	J	0
VK4110/VK4115	B	50	C	10
VK4120/VK4125	B	50	B	50

The class B closing force 2nd valve can also be provided with reduced opening speed, the max. dead time is then 1 s max. and the outlet pressure shall reach 5 mbar within 3 s from start of flow.

Table 7: Main valve (class J only) opening characteristics softlite versions

Softlite number	Inlet pressure (mbar)	Kind of gas	Dead time (s) max		Outlet pressure (mbar) 1.5 s after start of flow (in min. position)	Outlet pressure (mbar) 1.5 s after start of flow (in max. position)
			Upright position	Horizontal position		
3	20	G 20/25	1.8	1.5	1 ... 3.5	> 12
5 7	20	G 20/25	1.2	1.0	2.5 ... 6.0 4.5 ... 7.5	> 12
7	37	G 30/31	1.5	1.2	2.5 ... 6.5	> 16
7	50	G 30/31	1.2	1.0	2.5 ... 6.5	> 19

* The adjusted outlet pressure will be reached between 5 and 15 seconds from start of flow

Electrical data

Table 8: Electrical connection for Direct Burner Ignition systems

Supply voltage	Coil indication	Rectifier circuit position	Coil connection (See fig. 3.)	Valve indication
24 Vac, 50/60 Hz	24 Vrac	External	Series connection pin1 and pin 5 or plug 45.900.441-029	VK 81.5
24 Vac, 50/60 Hz	24 Vrac	In plug	Plug 45.900.441- (see table 9.)	VK 81.5
100 Vac, 50/60 Hz	100 Vrac	External	Series connection pin1 and pin 5	VK 41.5
110 Vac, 50/60 Hz	110 Vrac	In S4575	Select plug 45.900.441-033 without rectifier	VK 41.5
		In plug	Select plug 45.900.441-039	VK 41.5
		External	Series connection pin 1 and pin 5	VK 41.5
220 ... 240 Vac, 50/60 Hz	220 ... 240 Vrac	In S4565	S4565 type or plug 45.900.441- (see table 9.)	VK 41.5
220 ... 240 Vac, 50/60 Hz	220 ... 240 Vrac	In plug	Plug 45.900.441-(see table 9.)	VK 41.5
220 ... 240 Vac, 50/60 Hz	220 ... 240 Vrac	External	Series connection pin1 and pin 5	VK 41.5

Table 9: Electrical connection for Intermittent Pilot ignition systems

Supply voltage	Coil indication	Rectifier circuit position	Coil connection (See fig. 3.)	Valve indication
24 Vac, 50/60 Hz	24 Vrac	External	Parallel connection pin1/2 and pin 4/5	VK 81.0
220 ... 240 Vac, 50/60 Hz	220 ... 240 Vrac	In S4565 and S4585 types	S4565 and S4585 types	VK 41.0
220 ... 240 Vac, 50/60 Hz	220 ... 240 Vrac	External	Parallel connection pin1/2 and pin 4/5	VK 41.0
220 ... 240 Vac, 50/60 Hz	220 ... 240 Vrac	CVBC	Parallel connection pin1/2 and pin 4/5	VK 41.0

Electrical connection

The 24 V and 220/240 V versions gas controls can be connected to any standard DBI control with a 24 Vac, or 220/240 Vac output by using a rectifier plug 45.900.441- see table 10.

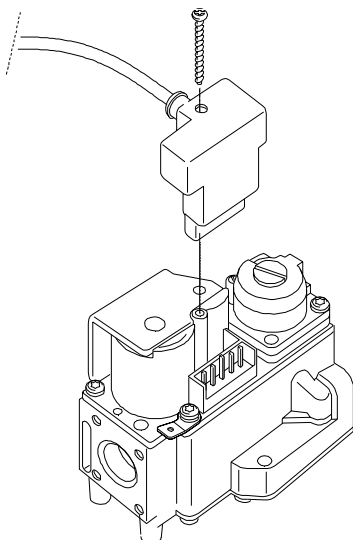

Fig. 2. Mounting of rectifier plug

IMPORTANT

Warranty claims are not accepted if not the specified plug/rectifier circuit is used.

Electrical protection of gas control with rectifier plug
IP 40

Mounting of rectifier plug

See fig. 2.

Mounting screw of rectifier plug

Torque: 40 Ncm max.

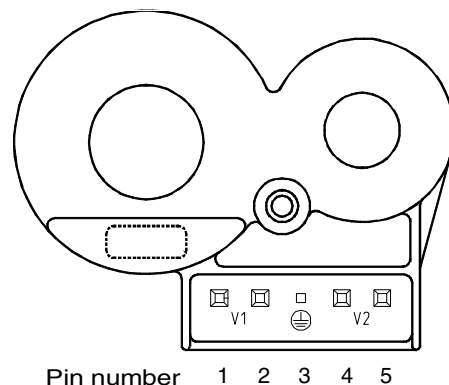

Fig. 3. Coil connection

Table 10: Rectifier Plug

Order number	Supply voltage	Wires	Cable length (mm)	Plug			Cable end			
				config	Rectifier	screw	config	strip length (mm)	Special	Finish
45.900.441-011	220/240	3	145	fig. 25	yes	in bag	fig 20	75		solder dip
45.900.441-012	24	2	500	fig. 25	yes	in bag	fig 22			
45.900.441-013	220/240	3	500	fig. 25	yes	in bag	fig 20	50		splices
45.900.441-014	220/240	3	620	fig. 25	yes	no	fig 20	80		solder dip
45.900.441-015	24	2	500	fig. 25	yes	in bag	fig 20	50		splices
45.900.441-016	220/240	3	240	fig. 25	yes	in bag	fig 20	150		solder dip
45.900.441-017	220/240	3	150	fig. 25	yes	in bag	fig 20	40		solder dip
45.900.441-018	220/240	3	800	fig. 25	yes	in bag	fig 20	75		solder dip
45.900.441-019	24	2	50	fig. 25	yes	inserted	fig 23			
45.900.441-021	24	2	720	fig. 25	yes	in bag	fig 20	80		solder dip
45.900.441-022	24	2	720	fig. 25	yes	inserted	fig 21			
45.900.441-023	24	2	1260	fig. 25	yes	in bag	fig 20	80		solder dip
45.900.441-024	24	2	1260	fig. 25	yes	inserted	fig 21			solder dip
45.900.441-025	220/240	3	600	fig. 25	yes	no	fig 20	130		solder dip
45.900.441-026	220/240	3	1500	fig. 25	yes	in bag	fig 20	50		solder dip
45.900.441-027	220/240	3	580	fig. 24	yes	inserted	fig 21 *		* earth wire = 6.5 faston female	
45.900.441-028 (as -027, but single packed in bag)	220/240	3	580	fig. 24	yes	inserted	fig 21 *		* earth wire = 6.5 faston female	
45.900.441-029	24 Vdc	2	500	fig. 24	no	in bag	fig 20	50		splices
45.900.441-030	220/240	3	500	fig. 25	yes	no	fig 20	50		splices
45.900.441-031 (for IP application)	220/240	4	700	fig. 25	double	in bag	fig 20	50		splices
45.900.441-032	220/240	3	1050	fig. 25	yes	no	fig 20	150		splices
45.900.441-033	220/240 Vdc	3	500	fig. 25	no	inserted	fig 20	50		splices
45.900.441-035	220/240	3	403	fig. 25	yes	inserted	fig 20	special	special earth wire	solder dip
45.900.441-036	220/240	3	570	fig. 25	yes	inserted			stocko connectors	
45.900.441-037	220/240	3	1800	fig. 25	yes	in bag	fig 20	50		solder dip
45.900.441-038	220/240	3	397	fig. 25	yes	inserted			stelvio connectors earth wire stripped	splices
45.900.441-039	110	3	500 mm	fig. 25	yes	in bag	fig 20	50		solder dip

Table 11: Current and power consumption

Nominal voltage	Current at nominal voltage (mA)		Power consumption at nominal voltage (W)	
	1 st operator	1 st + 2 nd operator	1 st operator	1 st + 2 nd operator
DBI system				
24 Vac, 50 Hz	--	424	--	9.2
100 Vac, 50 Hz	--	105	--	9.75
110 Vac, 50 Hz	--	89	--	10.8
220 Vac, 50 Hz	--	48	--	9.4
240 Vac, 50 Hz	--	52	--	11.2
IP system				
24 Vac, 50 Hz	309	309+143	6.7	6.7+3.1
220 Vac, 50 Hz	46	24	9.1	4.8
240 Vac, 50 Hz	50	26	10.9	5.7
220 Vac, 50 Hz*	31	31+11.0	7	7+2.2
240 Vac, 50 Hz*	35	35+12.1	8	8+2.6

* External rectifier

INSTALLATION

IMPORTANT

Take care that installer is a trained experienced service man.

Turn off gas supply before starting installation.

Disconnect power supply to prevent electrical shock and/or equipment damage.

Do not remove seals over inlet and outlet until the device is ready to be installed.

Take care that dirt cannot enter the gas control during handling.

Mounting position

The gas control can be mounted 0 to 90 degrees in any direction from the upright position (from the position when the operators are on top).

Main gas connection

Gas controls with internal thread

- Take care that dirt cannot enter the gas control during handling.
- Use a sound taper fitting with thread according to ISO 7-1 or a piece of new, properly reamed pipe, free from swarf.
- Do not thread or tighten the pipe or pipe fitting too far (see table below). Otherwise distortion and malfunction could result.

Pipe size (inch)	Max. length of pipe thread (mm)
$\frac{3}{8}$	14
$\frac{1}{2}$	18.6

- Apply a moderate amount of good quality thread compound to the pipe or fitting only, leaving the two end threads bare. PTFE tape may be used as an alternative.
- Tighten gas control using the right open end wrench. See fig. 4.

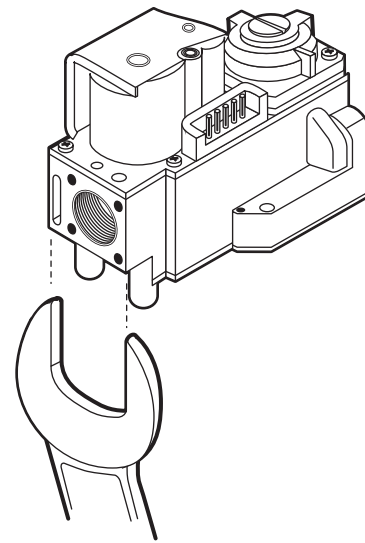

Fig. 4.

- Ensure the gas flows in the same direction as the arrow on the bottom of the gas control.

Gas controls for flange connection

- Insert "O"-ring in the groove of each flange. If necessary grease "O"-ring slightly to keep it in place.
- Mount gas control between flanges using the four screws for each flange.

Gas controls with external thread connection



WARNING

Fastening torque flat sealing ring only applicable for type Klingersil C4324

- ❶ With nut and flat sealing ring for pipe 14 mm (see fig 5.)
 Nut: drawing:45.006.583-005
 Flat sealing ring size: $\text{Ø}18 \times \text{Ø}10 \times 1.5$ mm:
 drawing45.006.582-002
 Fastening torque: maximum 40 Nm
 minimum 25 Nm
 Pipe end construction: see fig.: 8.
- ❷ With nut and flat sealing ring for pipe 15 mm (see fig 5.)
 Nut: drawing:45.006.583-004
 Flat sealing ring size: $\text{Ø}18 \times \text{Ø}10 \times 1.5$ mm
 drawing45.006.582-002
 Fastening torque: maximum 40 Nm
 minimum 25 Nm
 Pipe end construction: see fig.: 9.

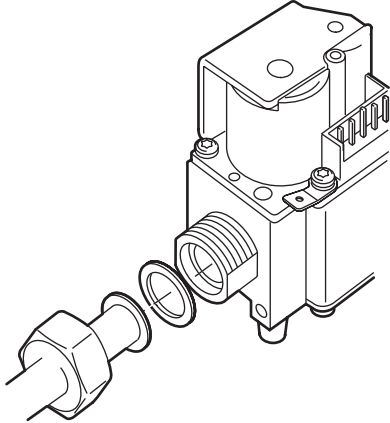

Fig. 5. External thread connection with nut and flat sealing ring

- ❸ With nut and olive (see fig. 6.)
 Pipe diameter: 15 mm
 Nut: drawing:45.006.583-003
 Fastening torque: maximum 50 Nm
 minimum 30 Nm
 Pipe end construction: square off end of tubing and remove burrs.

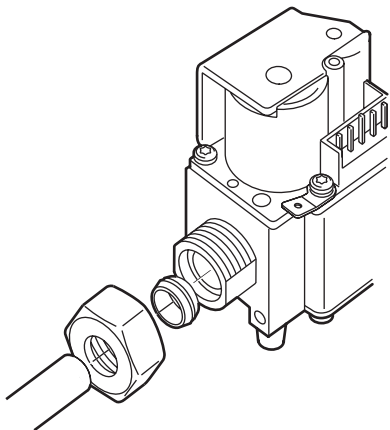

Fig. 6. External thread connection with nut and olive

- ❹ With nut and "O"-ring (see fig 7.)
 Pipe diameter: 15 mm
 Nut: drawing:45.006.583-003
 "O"-ring size: $\text{Ø}14.3 \times \text{Ø}2.4$ mm
 drawing45.006.528-048
 Fastening torque: maximum 50 Nm
 minimum 10 Nm
 Pipe end construction: see fig.: 10.

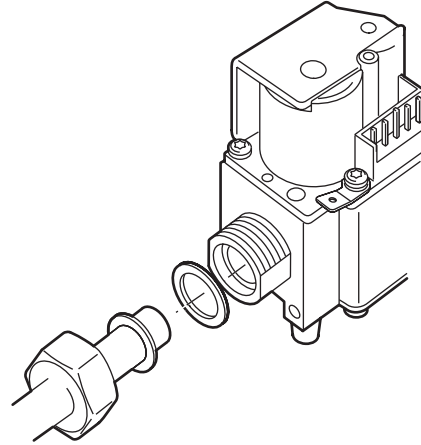

Fig. 7. External thread connection with nut and "O"-ring

- ❺ With nut and flat sealing ring for pipe 15 mm (see fig 5.)
 Nut: drawing:45.006.583-003
 Flat sealing ring size: $\text{Ø}24 \times \text{Ø}16 \times 1.5$ mm
 drawing45.006.582-001
 Fastening torque: maximum 50 Nm
 minimum 30 Nm
 Pipe end construction: see fig.: 11.
- ❻ With nut and flat sealing ring for pipe 18 mm (see fig 5.)
 Nut: drawing:45.006.583-002
 Flat sealing ring size: $\text{Ø}24 \times \text{Ø}16 \times 1.5$ mm
 drawing45.006.582-001
 Fastening torque: maximum 50 Nm
 minimum 30 Nm
 Pipe end construction: see fig.: 12.



Fig. 8. Pipe (dia 14 mm) for flat sealing ring connection

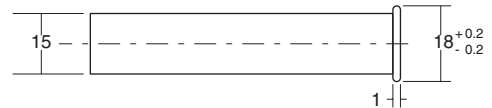

Fig. 9. Pipe (dia 15 mm) for flat sealing ring connection

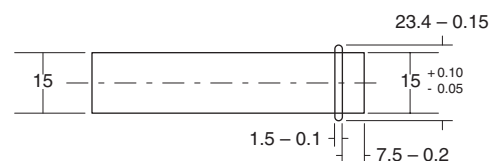

Fig. 10. Pipe end for "O"-ring connection

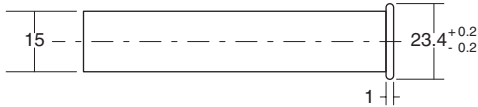

Fig. 11. Pipe (dia 15 mm) for flat sealing ring connection

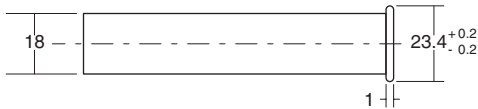

Fig. 12. Pipe (dia 18 mm) for flat sealing ring connection

Pressure feedback connection

WARNING

To avoid decreasing of performance of pressure regulator by pinching off the pressure feedback tubing, it is recommended to use a metal tubing.

Pilot gas connection at outlet side (if applicable)

- Square off the end of tubing and remove burrs.
- Slip compression fitting over 4 mm tubing.
- Insert tubing into gas control housing until it bottoms, slide fitting into place and turn finger tight.
- Use a wrench to tighten fitting about 1 1/2 turn beyond finger tight to shear of the olive.

Do not use jointing compound.

Connect other end of tubing to pilot burner according to the manufacturer's instructions.

CAUTION

Do not bend tubing at gas control after compression fitting has been tightened, as this may result in gas leakage at the connection.

Perform gas leak test

WARNING

FIRE OR EXPLOSION HAZARD CAN CAUSE PROPERTY DAMAGE, SEVERE INJURY OR DEATH

Check for gas leaks with a rich soap and water solution any time work is done on a gas control.

Gas leak test

- Paint all pipe connections upstream of the gas control with with a rich soap and water solution. Bubbles indicate a gas leak.
- If a gas leak is detected, tighten the pipe connection.
- Stand clear while lighting the main burner to prevent injury caused from hidden gas leaks, which could cause flashback in the appliance vestibule. Light the main burner.
- With the main burner in operation, paint all pipe joints (including adapters) and gas control inlet and outlet with with a rich soap and water solution or an approved leak detection fluid.
- If another gas leak is detected, tighten adapter screws, joints and pipe connections.
- Replace the part if gas leak can not be stopped.

CAUTION

Keep soap and water solution away from electrical connections.

Electrical connections

IMPORTANT

Disconnect power supply to prevent electrical shock and/or equipment damage.

Wiring must be in accordance with local regulations. The appliance manufacturer's instructions should always be followed when provided. If such instructions are not provided see the connection diagrams for typical systems.

Before installing or replacing any control check that type number is correct for the application.

Ensure combustion chamber is free of gas before start up.

Conduct a thorough check out when installation is completed.

At the first start the ignition control can be in lock out; depress reset button to free control.

Wiring

- Use leadwire which can withstand 105 °C ambient.
- Use leadwire which is proven against moisture.
- Wiring between automatic ignition control and spark sensing probe should have good quality insulation, suitable for the temperatures encountered.

Fusing

In order to prevent unsafe conditions at too high current, the automatic ignition controller has an integral non replaceable fuse.

This fuse will be blown long before the maximum 16 A external fuse switches off.

Spark gap

Max. allowable spark gap 3.5 mm

Supply voltage polarity

WARNING

If ignition control seems to operate normally but does not detect flame, check for right polarity of power supply (line, neutral).

Checking flame current

- The minimum value should be in accordance with the specified value of the ignition control.
- To check flame current connect a DC micro-Ampèremeter between flame sensing wire and flame sensing rod.
- If flame current is insufficient check that flame sensing rod is fully enveloped by the flame and that burner is reliable grounded to ignition control.
- If there is no sufficient flame current due to phase-phase mains it is recommendable to use a AT7030A or AT7030B flame detection transformer. See also EN1R-9136 instruction sheet AT7030.

WARNING

Short μ A meter during ignition to prevent damage of the μ A meter in single rod application.

ADJUSTMENTS AND FINAL CHECKOUT



WARNING

Adjustments must be made by qualified persons only. If the appliance manufacturer supplies checkout and/or service and maintenance instructions carefully follow them. If these instructions are not provided then use the procedure outlined below.

Outlet pressure adjustment on/off versions (see fig. 1.)

- Disconnect pressure feedback connection (if applicable)
- Start-up appliance in order to have gas input to burner.
- Check gas input to the appliance using a clocking gas meter or alternatively a pressure gauge connected to the outlet pressure tap.
- Remove cap screw to expose pressure regulator adjustment screw.
- Slowly turn adjustment screw with a small screw driver until the burner pressure required is recorded on the pressure gauge. Turn adjustment screw clockwise to increase or counter-clockwise to decrease gas pressure to the burner.
- For non-regulating mode (LP gas) turn adjustment screw clockwise until it stops.
- Replace pressure regulator cap screw.
- Connect pressure feedback connection (if applicable).

Check of slow opening (Softlite)

The Softlite pressure is factory set.

Check burner performance at this pressure observing burner ignition and flame characteristics. Burner should ignite promptly and without flash back to orifice and all ports should remain lit.

Cycle burner several times (wait 15 seconds between cycles to allow servo system to resume slow open action).

Repeat check of slow opening after allowing the appliance to cool down.

Adjustable Softlite (see fig. 1.)

For versions with adjustable Softlite the pressure can be adapted to optimise the ignition or to change over to another gas type.

- Check the ignition as described under "Check of slow

opening".

- Turn the appliance off.
- Remove the dust cap.
- Turn the adjustment screw one step in the direction "MAX" to increase or in the direction "MIN" to decrease the Softlite pressure.

NOTE: Change over from natural gas to LP gas by turning from min. to max.

- Start up the appliance and check the ignition, and repeat the adjustment if needed.
- Replace dust cap.

Final checkout of the installation

Set appliance in operation after any adjustment and observe several complete cycles to ensure that all burner components function correctly.

Honeywell

Home and Building Control Combustion Control Center Europe

Honeywell BV
Phileas Foggstraat 7
7821 AJ Emmen
The Netherlands
Tel.: +31 (-)591 695911
Fax: +31 (-) 591 695200
<http://europe.hbc.honeywell.com>